

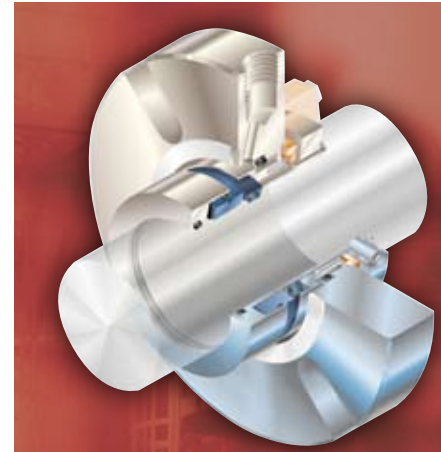

CPM Series

Durable single and dual cartridge seals

CPM Series seals succeed in the challenging application demands of the Corn Wet Milling industry. The combination of single and dual cartridge pusher seal configurations provide versatility to satisfy a full range of exacting conditions from the solids of corn steep to the light specific gravity applications of ethanol refining. CPM seals have proven performance in field applications and are capable of meeting the market's high performance expectations.



Features and Benefits

- Robust rotary face design is flexibly mounted, enhancing the ability to survive shock and face distortion typically found in clamped seal face designs.
- Automatic face on face alignment is a result of the floating stationary assembly's ability to accommodate out-of-square misalignment of the pump
- Springs located outside the process fluid deter chemical stress corrosion and spring clogging by dirty process fluids.
- Direct sintered silicon carbide and graphitized sintered silicon carbide hard face combinations tolerate abrasive slurries and periodic off design pump operating excursions.
- Hydraulically balanced seal design reduces friction, heat and wear with lower loading forces while maintaining a lubrication film between the mating faces.
- Dual seal designs are double balanced allowing for pre-surized or non-pressurized operation.
- Gland specifications to fit large bore seal chambers or standard bore stuffing boxes are standard.
- Maximized flow design for cooler seal operation with dual seal buffer/barrier circulation.
- Flush port standard for single seal configurations.
- Throttle bushing option available for increased safety on single seals.
- Factory pre-assembled and air tested for reliable equipment start-up.

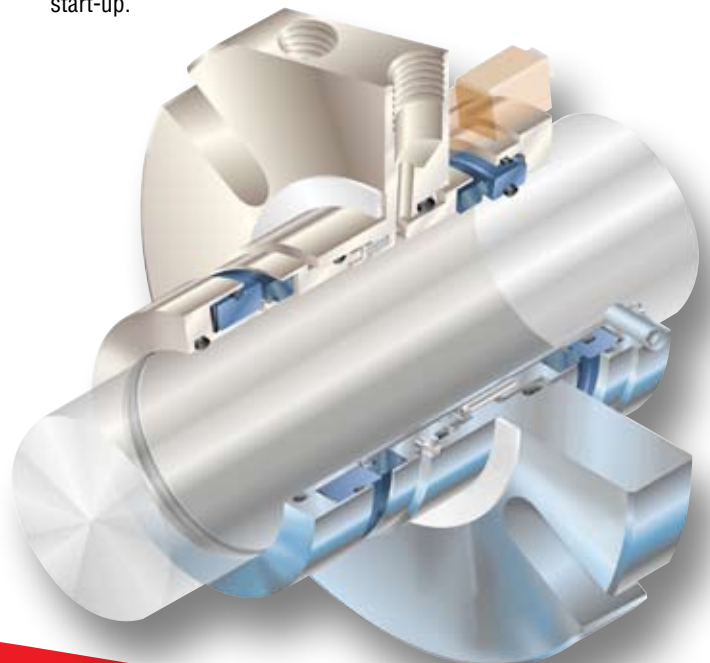

Operating Parameters

Maximum Pressure	vacuum to 400 psig (27 bar)
Temperature	-40 to 400°F (-40 to 204°C)
Maximum Speed	100 ft/min (30 m/s)
Specific Gravity	>0.6

Materials of Construction

Metal Parts	316 Stainless Steel
Mating Ring	Direct Sintered Silicon Carbide (DSSC)
Primary Ring	Carbon, Graphitized Sintered Silicon Carbide
Elastomers	Aflas ¹ , Fluoroelastomer
Springs	Alloy C-276

¹ Registered Trademark of Asahi Glass Co., Ltd

Dimensional Data for standard bore seal chambers (inches) CPM PX Single Seals

A	C	D	E	F	G	J	K	L	M	
Shaft & Seal Size	Box Bore (Min) (Max)	Gasket OD	Gland OD	INBD Seal Dim	Box Depth (Min)	OTBD Seal Dim	Dist to Obst. (Min)	Slot Bolt Circle	Bolt Slot Dia	
1.125	1.750	2.135	2.375	4.000	1.052	1.114	1.636	1.698	2.868	0.438
1.375	2.000	2.385	2.625	4.000	1.052	1.114	1.636	1.698	3.212	0.531
1.750	2.500	2.760	3.000	5.500	1.052	1.114	1.636	1.698	3.587	0.531
1.875	2.625	2.885	3.125	5.500	1.052	1.114	1.636	1.698	3.712	0.531
2.000	2.750	3.010	3.250	5.400	1.052	1.114	1.636	1.698	3.837	0.531
2.125	2.875	3.135	3.375	6.000	1.052	1.114	1.636	1.698	4.118	0.688
2.375	3.375	3.885	4.125	6.000	1.052	1.114	1.636	1.698	4.864	0.688
2.500	3.250	3.760	4.000	6.000	1.052	1.114	1.636	1.698	4.989	0.688
2.625	3.625	4.135	4.375	6.000	1.052	1.114	1.636	1.698	5.114	0.688
2.750	3.750	4.260	4.500	7.000	0.887	0.949	1.801	1.863	5.239	0.688
3.000	4.000	4.510	4.750	8.000	0.887	0.949	1.801	1.863	5.489	0.688
3.250	4.375	5.135	5.375	8.000	1.548	1.610	2.298	2.360	6.345	0.813
3.750	4.750	5.510	5.750	8.750	0.920	0.982	1.801	1.863	6.708	0.813
4.750	5.750	6.573	6.813	9.500	1.324	1.386	2.271	2.333	7.719	0.813

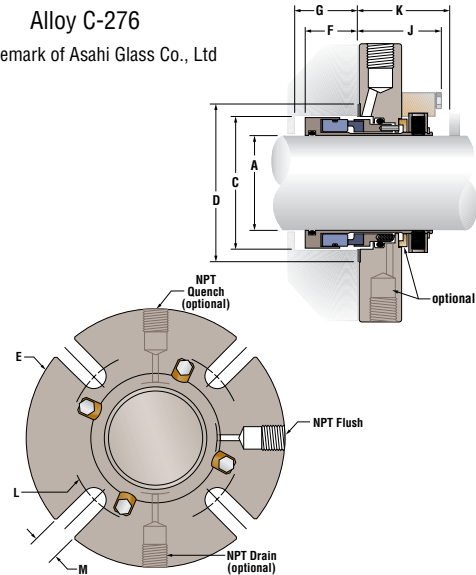

Dimensional Data for standard bore seal chambers (inches) CPM PP Dual Seals

A	C	D	E	F	G	J	K	L	M	
Shaft & Seal Size	Box Bore (Min) (Max)	Gasket OD	Gland OD	INBD Seal Dim	Box Depth (Min)	OTBD Seal Dim	Dist to Obst. (Min)	Slot Bolt Circle	Bolt Slot Dia	
1.125	1.750	2.135	2.375	4.000	2.035	2.097	2.119	2.181	2.868	0.438
1.375	2.000	2.385	2.625	4.000	2.035	2.097	2.119	2.181	3.212	0.531
1.750	2.500	2.760	3.000	5.500	2.035	2.097	2.119	2.181	3.587	0.531
1.875	2.625	2.885	3.125	5.500	2.035	2.097	2.119	2.181	3.712	0.531
2.000	2.750	3.010	3.250	5.400	2.035	2.097	2.119	2.181	3.837	0.531
2.125	2.875	3.135	3.375	6.000	2.035	2.097	2.119	2.181	4.118	0.688
2.375	3.375	3.885	4.125	6.000	1.945	2.007	2.119	2.181	4.864	0.688
2.500	3.250	3.760	4.000	6.000	2.035	2.097	2.119	2.181	4.989	0.688
2.625	3.625	4.135	4.375	6.000	1.945	2.007	2.119	2.181	5.114	0.688
2.750	3.750	4.260	4.500	7.000	1.820	1.882	2.244	2.306	5.239	0.688
3.000	4.000	4.510	4.750	8.000	1.820	1.882	2.244	2.306	5.489	0.688
3.250	4.375	5.135	5.375	8.000	2.468	2.530	3.073	3.135	6.345	0.813
3.750	4.750	5.510	5.750	8.750	1.688	1.750	2.798	2.860	6.708	0.813
4.750	5.750	6.573	6.813	9.500	2.230	2.292	3.048	3.110	7.719	0.813

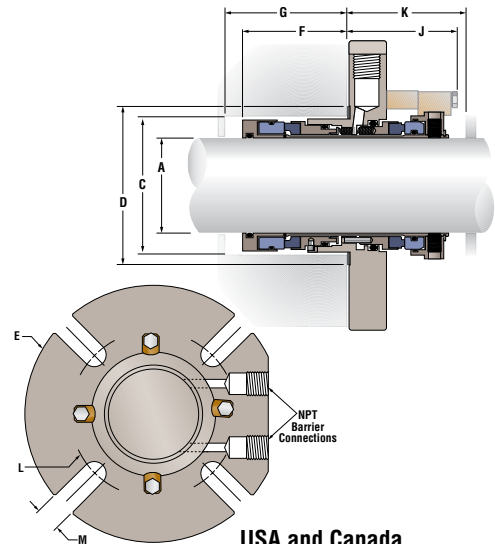

FSD199eng REV 07-10 Printed in USA

To find your local Flowserve representative and find out more about Flowserve Corporation visit www.flowserve.com

USA and Canada
 Kalamazoo, Michigan USA
 Telephone: 1 269 381 2650
 Telefax: 1 269 382 8726

Europe, Middle East, Africa
 Roosendaal, The Netherlands
 Telephone: 31 165 581400
 Telefax: 31 165 554590

Asia Pacific
 Singapore
 Telephone: 65 6544 6800
 Telefax: 65 6214 0541

Latin America
 Mexico City
 Telephone: 52 55 5567 7170
 Telefax: 52 55 5567 4224

Flowserve Corporation has established industry leadership in the design and manufacture of its products. When properly selected, this Flowserve product is designed to perform its intended function safely during its useful life. However, the purchaser or user of Flowserve products should be aware that Flowserve products might be used in numerous applications under a wide variety of industrial service conditions. Although Flowserve can provide general guidelines, it cannot provide specific data and warnings for all possible applications. The purchaser/user must therefore assume the ultimate responsibility for the proper sizing and selection, installation, operation, and maintenance of Flowserve products. The purchaser/user should read and understand the Installation Instructions included with the product, and train its employees and contractors in the safe use of Flowserve products in connection with the specific application.

While the information and specifications contained in this literature are believed to be accurate, they are supplied for informative purposes only and should not be considered certified or as a guarantee of satisfactory results by reliance thereon. Nothing contained herein is to be construed as a warranty or guarantee, express or implied, regarding any matter with respect to this product. Because Flowserve is continually improving and upgrading its product design, the specifications, dimensions and information contained herein are subject to change without notice. Should any question arise concerning these provisions, the purchaser/user should contact Flowserve Corporation at any one of its worldwide operations or offices.