

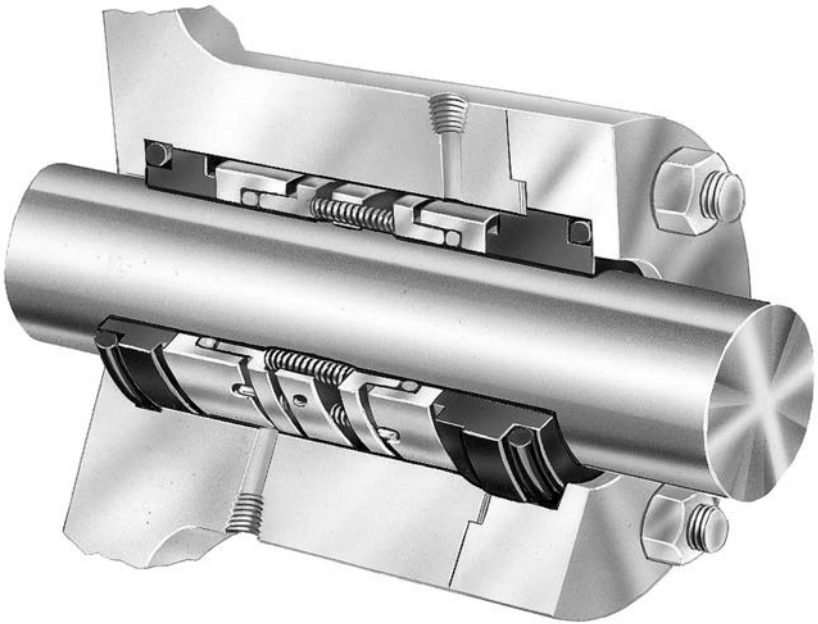

Installation Instructions

Dual Pressurized Seals

Dual RO, RO-TT, PTO, PT, RO-PTT,
BRO, BRT, MRO, MRT, and other
component seals



1 Equipment Check

1.1 Follow plant safety regulations:

- lock out motor and valves.
- wear designated personal safety equipment.
- relieve any pressure in system.
- consult plant MSDS files for hazardous material regulations.

1.2 Adjust the bearings, coupling, and impeller so that the shaft is in its operating axial position. **Disassemble equipment to allow access to seal installation area.**

1.3 Remove all burrs and sharp edges from the shaft and sleeve including sharp edges of keyways and threads. Replace worn shaft or sleeve. Make sure the seal housing bore, face, and sealing fluid flush taps are clean and free of burrs and sharp edges than might damage O-rings, V-rings, or Duraflex rings.

Seal Chamber Requirements

Figure 1

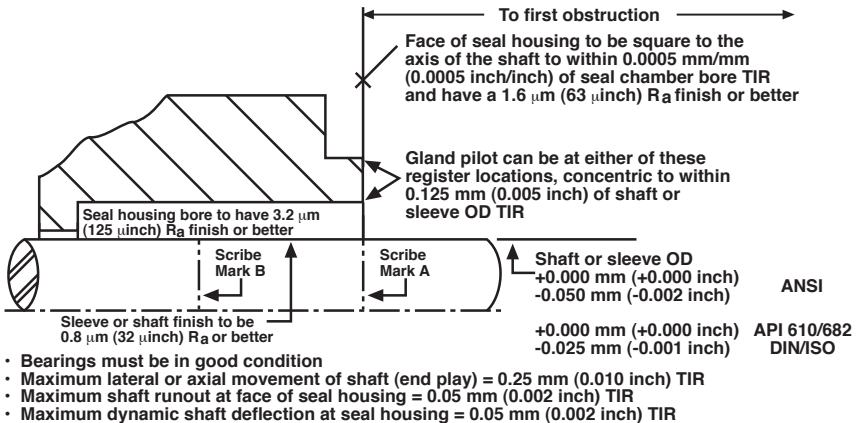

1.4 Check requirements for shaft, sleeve, and seal housing. See Figure 1.

1.5 Check assembly drawing included with the dual seal for specific seal design, materials of construction, dimensions, and piping connections.

1.6 Check shaft or sleeve OD, box depth, box bore, and distance to the first obstruction to ensure that they are dimensionally the same as shown on the seal assembly drawing.

The images of parts shown in these instructions may differ visually from the actual parts due to manufacturing processes that do not affect the part function or quality.

- 1.7 **Check gland pilot and bolt holes** to ensure they are adaptable to the equipment and are the same as shown on the assembly drawing.
- 1.8 **Handle all seal parts with care**, they are manufactured to precise tolerances. The sealing faces are of special importance and are lapped flat to within three light bands (34.8 millionths of an inch). **Keep the seal faces perfectly clean at all times.**

Dual Seal Installation

2 Single End Suction Vertical Split Case and Vertical In-Line Pumps (1 seal chamber)

- 2.1 **Scribe Mark A** on the shaft or sleeve **at the face of the seal housing**, Figure 1. Refer to the assembly drawing provided with the seal for the seal setting dimensions. **Scribe Mark B**, Figure 1, at this dimension from Scribe Mark A. (See Section 4 for ball drive designs).
- 2.2 **Lubricate** one of the two **stationary face mounting O-rings** or Duraflex rings with the silicone lubricate provided with the seal and **nest this O-ring in the gland cavity. Press the outer stationary face into the gland** with the sealing surface orientated toward the inboard side of the gland. Use hand pressure only. **Position the gland** over the shaft or sleeve with the stationary face sealing surface orientated toward the seal chamber (stuffing box). Place the gland as close to the bearing bracket as possible. Do not bump the stationary face against the shaft as it may chip, crack, or break.
- 2.2 **Lubricate the shaft** or sleeve with the silicone lubricant provided.
- 2.3 **Install the rotating seal assembly** on the shaft or sleeve:
 - **Outer rotating face** with **rotating face gasket** O-ring, V-ring, or Duraflon wedge.
 - **Seal assembly.**
 - **Inner rotating face** with **rotating face gasket** O-ring, V-ring, or Duraflon wedge.

The rotating face sealing surfaces should be facing away from the springs and toward the stationary faces. Be sure that the seal drive pins engage the drive slots in the rotating faces.

The RO, PTO, and similar designs have buttoned seal assemblies that can most easily be installed on the shaft or sleeve as a unit with the rotating face gasket O-rings in place in the bore of the rotating faces. The BRO, MRO, and similar designs are generally larger in diameter and the rotating seal parts are most easily installed as individual components.

Handle Duraflon V-rings, wedge rings, Durafite, and Duraflex with extreme care. Duraflon V-rings must be assembled individually and not pushed on the shaft or sleeve while they are part of the rotating face or rotating seal assembly. Avoid nicking or pinching either lip of the V-ring. Use both V-rings, they work together to form an effective seal.

Position the rotating seal assembly in its final axial position with the indicated position of the seal drive lined up with Scribe Mark B. **Tighten the seal drive set screws** firmly and evenly.

- 2.4 **Lubricate the seal chamber bore** with the lubricant provided. The seal chamber is usually the stuffing box contained in the pump back plate.
- 2.5 **Lubricate the other stationary face gasket O-ring** and place it on the back shoulder of the inner stationary face. Slide the **inner stationary face** with the O-ring into position at the bottom of the chamber. The rubbing or sealing surface of the inner stationary face should face out, away from the impeller.
- 2.6 **Wipe the seal faces clean** with alcohol. Seal faces should not be lubricated but should be left clean and dry.
- 2.7 **Install the seal chamber (pump back-plate) and assemble the pump.** **Position the gland** to the face of the seal housing. Be sure the gland pilot is properly engaged. **Tighten the gland stud nuts** evenly, cross stagger the adjustment of the nuts. Follow the equipment manufacturer's recommendations for gland stud nut torque. In the absence of recommendations, gland nuts should only be torqued to establish a leak tight seal at the gasket. Proper gland bolt adjustment is especially important with a clamp style stationary face where excessive torque may damage the face.
- 2.8 **See Section 5, Operational Recommendations**, before starting pump.

3 Double Suction and Multistage Horizontal Split Case Pumps (2 seal chambers)

Note: The parting **gasket** between the upper and lower sections of the pump casing **must be flush** with the seal chamber bore and face or leakage will occur past the O-rings and gaskets.

- 3.1 **Scribe Mark A** on the shaft or sleeve **at the face of the seal housing**, Figure 1. Refer to the assembly drawing provided with the seal for the seal collar dimension setting shown in a box. **Scribe Mark B**, Figure 1, at this dimension from Scribe Mark A. (See Section 4 for ball drive designs).
- 3.2 **Lubricate the seal chamber bore** with the lubricant provided. The seal chambers are usually the stuffing boxes, located near the bearing brackets.
- 3.3 **Lubricate one of the stationary face mountings** and place it on the back shoulder of the inner stationary face. Slide the **inner stationary face** with the O-ring into position at the bottom of the chamber. The rubbing or sealing surface of the inner stationary face should face out, away from the pump impeller.
- 3.4 **Wipe the seal faces clean** with alcohol. Seal faces should not be lubricated but should be left clean and dry.
- 3.5 **Lubricate the shaft** or sleeve and **rotating gasket O-ring** with the silicone lubricant provided.

3.6 **Install the rotating seal assembly** on the shaft or sleeve:

- **Inner rotating face with rotating face gasket** O-ring, V-ring, or Duraflon wedge.
- **Seal assembly.**
- **Outer rotating face with rotating face gasket** O-ring, V-ring, or Duraflon wedge.

The rotating face sealing or rubbing surfaces should be facing away from the springs and toward the stationary face. Be sure that the seal drive ring drive pins engage the drive slots in the seal rings.

The RO, PTO, and similar designs have unitized seal assemblies, they can most easily be installed on the shaft or sleeve as a unit with the rotating face gasket O-rings in place in the bore of the rotating face. The BRO, MRO, and similar designs are generally larger in diameter and the rotating seal parts are most easily installed as individual components.

Handle Duraflon V-rings, wedge rings, Durafite, and Duraflex with extreme care. Duraflon V-rings must be assembled individually and not pushed on the shaft or sleeve while they are part of the rotating face or rotating seal assembly. Avoid nicking or pinching either lip of the V-ring. Use both V-rings, they work together to form an effective seal.

Position the rotating seal assembly in its final axial position with the indicated position of the seal drive lined up with Scribe Mark B. **Tighten the seal drive set screws** firmly and evenly.

3.7 **Lubricate** the other **stationary face gasket O-ring** or Duraflex ring with the silicone lubricate provided and nest this **O-ring in the gland cavity. Press the outer stationary face into the gland** with the sealing surface orientated toward the inboard side of the gland. Use hand pressure only.

3.8 **Position the gland** over the shaft or sleeve with the stationary face sealing surface orientated toward the seal chamber (stuffing box) and the gland or stationary pilot properly engaged. Do not bump the stationary face against the shaft as it may chip, crack, or break. **Tighten the gland stud nuts** evenly, cross stagger the adjustment of the nuts. Follow the equipment manufacturer's recommendations for gland stud nut torque. In the absence of recommendations, gland nuts should only be torqued to establish a leak tight seal at the gasket. Proper gland bolt adjustment is especially important with clamp style stationary faces where excessive torque may damage the face.

3.9 **Reassemble the pump.**

3.10 **See Section 5, Operational Recommendations,** before starting pump.

4 Ball Drive Seal Designs

The drive ball replaces the set screws in the seal drive and provides the following features:

- It compensates for axial shaft adjustment to reset the impeller
- It compensates for axial shaft movement due to thermal expansion or mechanical loading of the equipment.
- It provides for positive seal drive without the use of seal setting dimensions.

4.1 Follow the instructions in Section 2 or 3, **Scribe Mark A or B** are unnecessary.

4.2 **Slide the rotating seal assembly down the shaft** or sleeve until the predrilled indentation in the shaft or sleeve is directly under the spring gap. **Insert the ball** into the predrilled indentation. See Figure 2.

Figure 2

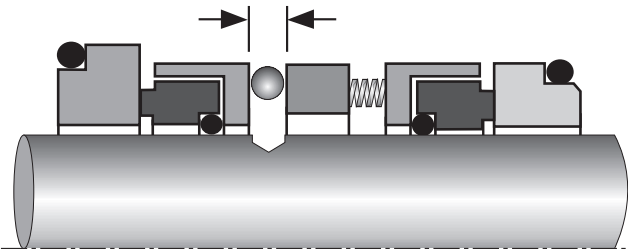

4.3 Slide the rotating seal assembly forward to **confine the ball** in the seal drive slot. See Figure 3.

Figure 3

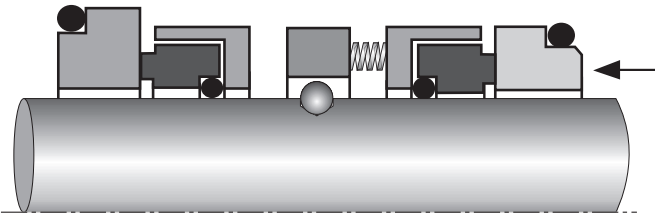

4.4 Complete the seal and pump assembly as instructed in Sections 2 and 3.

5 Operational Recommendations

See Figure 4 for a suggested sealing fluid supply system for Dual Pressurized Seal designs. For other systems using Supply Tanks or Circulators refer to the tank or circulator instructions or contact Flowserve.

- 5.1 The Dual Pressurized Seal requires a constant supply of a clean barrier fluid. Whenever the equipment is in operation **circulate clean barrier fluid** from a reliable external source between the seals in the seal chamber. Always **start up the barrier fluid supply system** before starting the equipment. Maintain the fluid pressure between the seals at least 103 kPa (15 psig) greater than the maximum pressure of the pumped product acting on the inner seal. Figure 4 shows Plan 53 with a pressurized supply tank and Plan 54 with an external support system. Do not exceed the pressure-velocity (P-V) limits of the seal, see the pressure-velocity curves for this seal.

Recommended Barrier Supply System for Dual Pressurized Seals

Figure 4

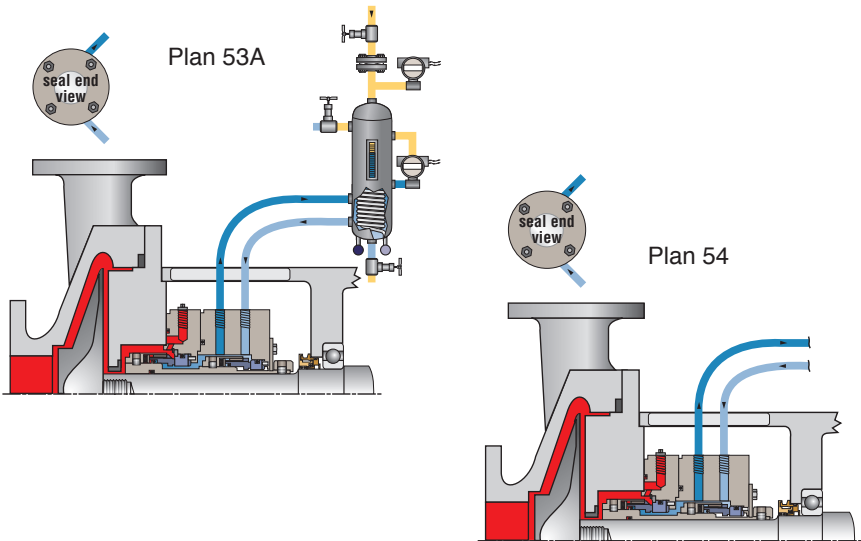

- 5.2 Do not start up the equipment dry. Vent air from the casing of the pump and the seal chamber before startup.
- 5.3 If the seal runs hot or squeals, check the seal housing dimensions to ensure that the seal is not over-compressed and inspect the barrier fluid supply system. Do not allow the equipment to run for any extended time if the seal gets hot or squeals.

For special problems encountered during installation, contact your nearest Flowserve Representative or Authorized Distributor.



TO REORDER REFER TO
B/M # _____
F.O. _____

6 Repair

This product is a precision sealing device. The design and dimension tolerances are critical to seal performance. Only parts supplied by Flowserve should be used to repair a seal. To order replacement parts, refer to the part code and B/M number. A spare backup seal should be stocked to reduce repair time.

When seals are returned to Flowserve for repair, **decontaminate the seal assembly** and include an order marked "**Repair or Replace.**" **A signed certificate of decontamination must be attached. A Material Safety Data Sheet (MSDS) must be enclosed** for any product that came in contact with the seal. The seal assembly will be inspected and, if repairable, it will be rebuilt, tested, and returned.

FIS106eng REV 06/15 Printed in USA

**To find your local Flowserve representative
and find out more about Flowserve Corporation,
visit www.flowserve.com**

Flowserve Corporation has established industry leadership in the design and manufacture of its products. When properly selected, this Flowserve product is designed to perform its intended function safely during its useful life. However, the purchaser or user of Flowserve products should be aware that Flowserve products might be used in numerous applications under a wide variety of industrial service conditions. Although Flowserve can provide general guidelines, it cannot provide specific data and warnings for all possible applications. The purchaser/user must therefore assume the ultimate responsibility for the proper sizing and selection, installation, operation, and maintenance of Flowserve products. The purchaser/user should read and understand the Installation Instructions included with the product, and train its employees and contractors in the safe use of Flowserve products in connection with the specific application.

While the information and specifications contained in this literature are believed to be accurate, they are supplied for informative purposes only and should not be considered certified or as a guarantee of satisfactory results by reliance thereon. Nothing contained herein is to be construed as a warranty or guarantee, express or implied, regarding any matter with respect to this product. Because Flowserve is continually improving and upgrading its product design, the specifications, dimensions and information contained herein are subject to change without notice. Should any question arise concerning these provisions, the purchaser/user should contact Flowserve Corporation at any one of its worldwide operations or offices.

© 2015 Flowserve Corporation

USA and Canada

Kalamazoo, Michigan USA
Telephone: 1 269 381 2650
Telefax: 1 269 382 8726

Europe, Middle East, Africa

Roosendaal, the Netherlands
Telephone: 31 165 581400
Telefax: 31 165 554590

Asia Pacific

Singapore
Telephone: 65 6544 6800
Telefax: 65 6214 0541

Latin America

Mexico City
Telephone: 52 55 5567 7170
Telefax: 52 55 5567 4224